

PROCESS DETAILS

Process	GLASS PASSIVATED MESA
Die Size	87 x 87 MILS
Die Thickness	12.2 MILS
Anode Bonding Pad Area	69.5 x 69.5 MILS
Top Side Metalization	Au - 5,000Å
Back Side Metalization	Au - 2,000Å

GEOMETRY

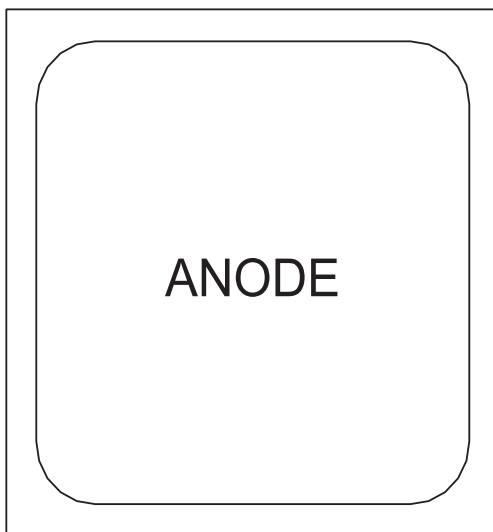

BACKSIDE CATHODE

R0

GROSS DIE PER 4 INCH WAFER

1,490

PRINCIPAL DEVICE TYPES

1N5802 thru 1N5806
UES1101 thru UES1106
CMR3U-01 Series

145 Adams Avenue
Hauppauge, NY 11788 USA
Tel: (631) 435-1110
Fax: (631) 435-1824
www.centalsemi.com

R3 (24-August 2006)

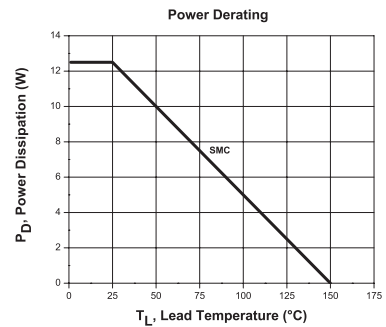
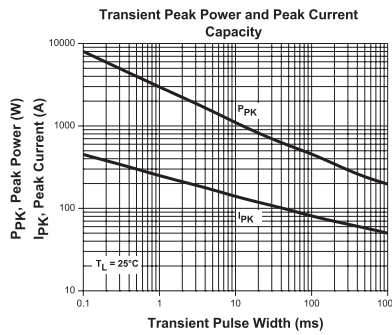
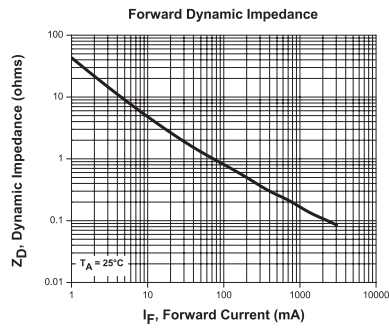
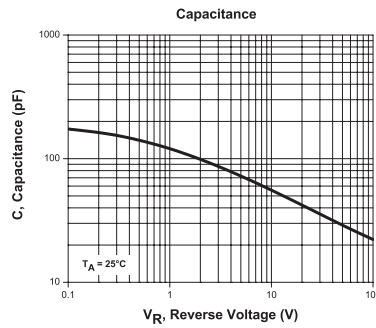
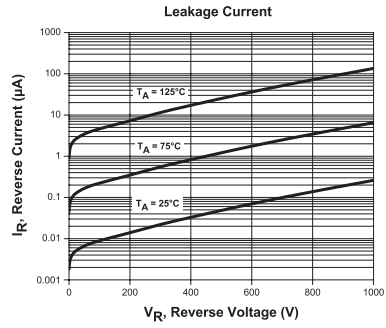
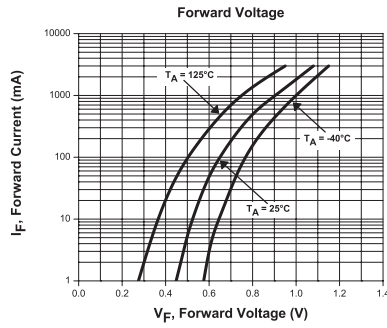

145 Adams Avenue
Hauppauge, NY 11788 USA
Tel: (631) 435-1110
Fax: (631) 435-1824
www.centra-semi.com

R3 (24-August 2006)